

Build Instructions

Inside you will find all the parts required to build your own JIK-DB1. Use this document to assist you as you begin to build your own direct box. You can also find a step by step video that you can watch at:

www.jensen-transformers.com/iso-kit-video

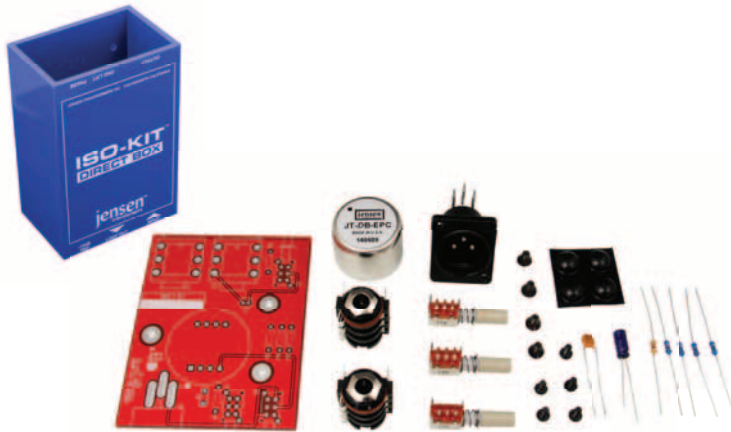

REF	QTY	Description	Color Code
R1	1	RES 51.1 Ω	Gr, Br, Br, Gd, Br
R2	1	RES 1.82K Ω	Br, Gry, Rd, Br, Br
R3	1	RES 8.25K Ω	Gry, Rd, Gr, Br, Br
R4	1	RES 15.0K Ω	Br, Gr, Bk, Rd, Br
R5	1	RES 6.81K Ω	Bl, Gry, Br, Br, Br
C1	1	CAP CER .01mF 100V	
C2	1	CAP ALUM 22μF 25V	
S1-S3	3	PUSH SWITCH	

Gr=Green, Br=Brown, Gd=Gold, Gry=Grey, Rd=Red, Bk=Black, Bl=Blue

Tools Required

- Side cutters
- Philips #1 screwdriver
- Philips #2 screwdriver
- Nutdriver 7/16"
- Soldering iron 25-40 watt and solder

Basic Instructions:

1. First, write your name in the space provided on the circuit board using a Sharpie felt pen.
2. **RESISTORS:** Start by placing the first resistor (R1) in the designated position. Bend the wire leads at 90 degree angles to feed the leads through the board. Spread the wire leads slightly to ensure the resistor stays in place. Solder the leads from the bottom of the board, then clip the excess wire leads. Repeat this for the remaining resistors R2-R5.
3. **CAPACITORS:** Place the first capacitor (C1) in the assigned designation. There is no polarity so you may install these in any direction. You do not need to bend the leads to fit, however after it's been inserted you can bend the wire slightly to secure in place. Solder the leads from the bottom of the board and then clip the excess wire leads. Repeat for C2.
4. **PUSH SWITCH:** Place the first push switch (S1) in the assigned designation. Make sure it is facing outwards from the board, flip the board over and ensure the switch is flush to the board, then solder the 8 pins. You do not need to clip the wire leads. Repeat for the remaining switches S2-S3.

PCB Layout

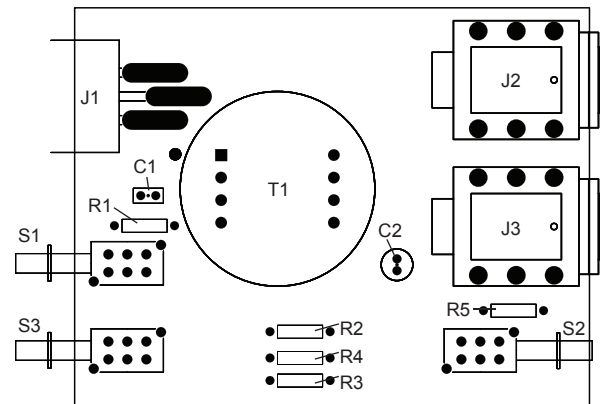

Soldering Hints:

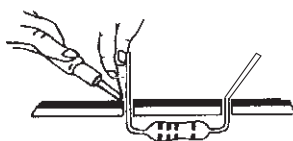

1. Mount the component against the PCB surface and bend the wire leads slightly.

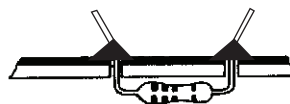

2. Solder the wire leads from the bottom, make sure the solder joints are cone-shaped and shiny.

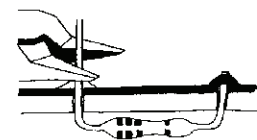

3. Trim excess wire leads as close as possible to the solder joint.

Basic Instructions (Continued):

5. **1/4" TRS JACK:** Place J3 in the assigned designation. Make sure the hole is facing outwards from the board, flip the board over and solder two leads on opposite sides of the input jacks to hold it in place. Then apply pressure while reheating the leads so the jack becomes flush with the circuit board. Solder the rest of the pins. You do not need to clip the wire leads for the jacks. Repeat this process for J2.

REF	QTY	Description
J1	1	XLR MALE JACK
J2-J3	2	TRS 1/4" JACK
T1	1	12:1 JT-DB-EPC TRANSFORMER
PCB	1	BARE JENSEN PCB

6. **TRANSFORMER:** Place the Jensen transformer into the T1 designation. Line up the dot on the transformer to the dot on the circuit board, then flip it over and solder it in the same way as the jacks. Solder two leads on opposite sides, then apply pressure to the transformer while reheating the soldered leads so it becomes flush with the board, then solder the rest of the leads. Use the side cutters to clip the excess wire leads.

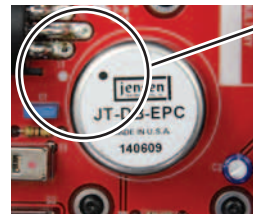

Line up the dot on the transformer to the dot on the circuit board.

7. **MOUNTING PCB:** Before placing the PC board into the metal insert, push the switches to the "IN" position to allow more clearance and place two orange washers on each of the jacks. Now you can position the PC board in place. Using the Philips #1 screwdriver, drive three of the rounded Philips screws to attach the PC board with the metal.

8. **XLR JACK:** Position the male XLR connector into the J1 designation so the pins are in the slots, then slide it up so the connector is flush with the metal. Now use the remaining two rounded philips screws to attach this to the metal. Be careful not to overtighten the screws as you can damage the threading on the XLR. To solder the pins into the slots, flip the ISO-Kit upside down and access the PC board by the hole in the bottom of the metal. Heat up the pin first and then apply a fair amount of solder. Repeat this for each pin.

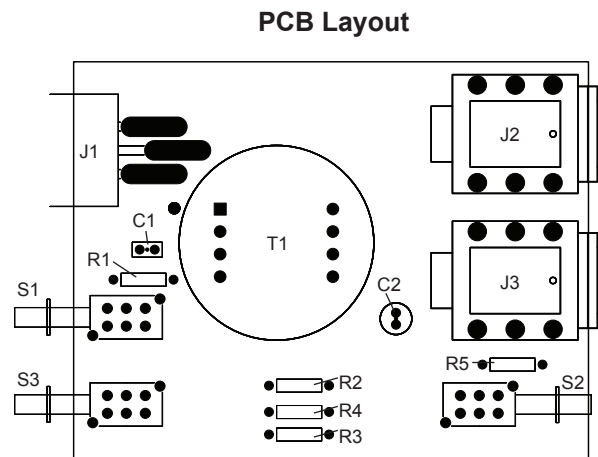

9. **SECURING TRS HEX-NUTS:** Insert the two metal hex-nuts into the two plastic black washers so the rounded sides are facing outwards, then using your hands gently screw these into the jacks. Once they are positioned, you can use the 7/16th nutdriver to tighten these (just past the tightness you can do with your fingers).

10. **SWITCH BUTTONS:** Push in the three beige push-on buttons. Align the beige buttons so that the square lines up, then push it in firmly with either your fingers or a blunt object such as the end of screwdriver.

11. **ASSEMBLY:** Slide the metal insert into the metal wrapper. Ensure that the side of the wrapper that says "OUTPUT" is on the same side as the XLR, and that the side that says "INPUT" and "LOOP OUT" corresponds with the two jacks. Flip the ISO-KIT over, and drive the four Philips countersunk screws with the Philips #2 screwdriver.

12. **RUBBER FEET:** Place the rubber feet onto the corners of the bottom of the ISO-KIT without blocking the screws.

13. **TEST:** Test the ISO-KIT by plugging in an instrument and amplifier and begin playing. Activate the PAD switch to hear the attenuation work correctly.



Watch the instructional video at
www.jensen-transformers.com/iso-kit-video