

# JT-11SSP-6M IN WHEATSTONE BRIDGE STEREO TO MONO COMBINER CIRCUIT

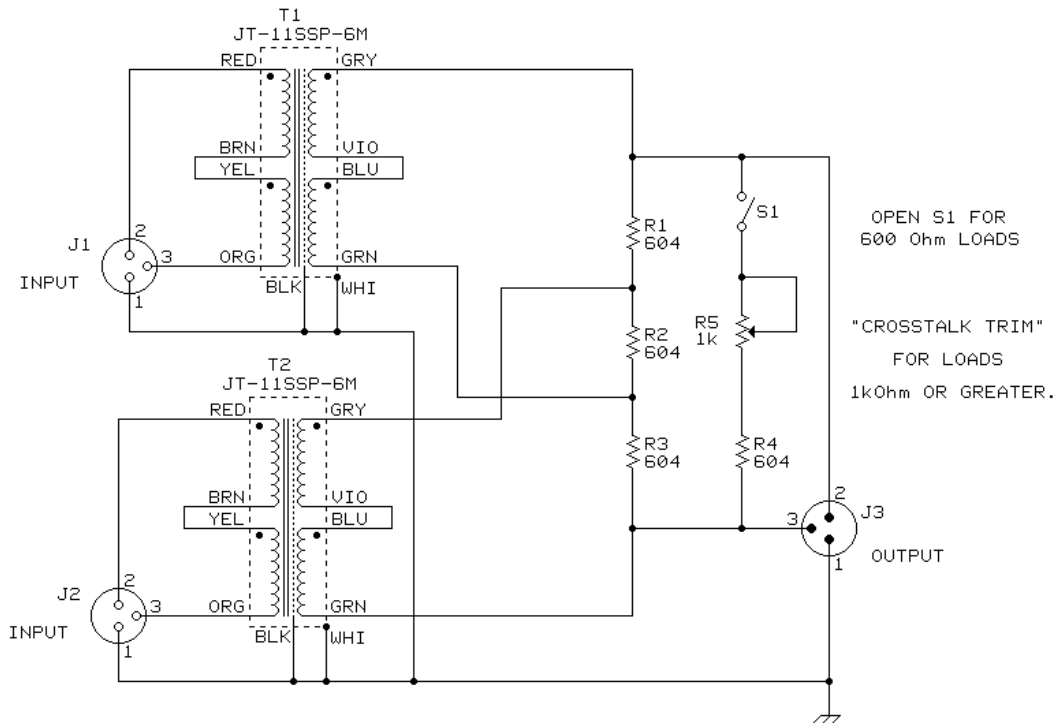

OPEN S1 FOR  
600 Ohm LOADS

"CROSSTALK TRIM"  
FOR LOADS  
1kOhm OR GREATER.

**NOTES:**

- 1) THE ADVANTAGE OF THIS TYPE OF CIRCUIT FOR STEREO TO MONO CONVERSION IS THAT WHEN PROPERLY TRIMMED, IT DOES NOT CAUSE ANY CROSSTALK BETWEEN CHANNELS.
- 2) THE DISADVANTAGES ARE THE LOW INPUT IMPEDANCE OF ONLY 745 OHMS, AND THE FACT THAT IT MUST BE TRIMMED EACH TIME THE LOAD IS CHANGED.

© COPYRIGHT 2002, JENSEN TRANSFORMERS, INC.

<b>jensen</b>	AS094
	08/21/02
7135 HAYVENHURST AVE. VAN NUYS, CALIFORNIA 91406 (818) 374-5857	