

DIN-PC Pro-to-consumer isolator

- Converts +4 dB balanced signals to -10 dB unbalanced
- Eliminates hum and buzz caused by ground loops
- Ruler flat frequency response from 10 Hz to 140 kHz
- Plug and play easy to use, no power required



The Iso•Max DIN-PC is a single channel pro-to-consumer isolator that is used to convert a +4 dBu line-level device to -10 dBV for consumer-level signals such as connecting the balanced output from a mixing desk to the unbalanced input of a hand-held video recorder or laptop.

The design begins with a gray molded assembly made from UL94-VO flame retardant Noryl that snaps into place onto a standard 35 mm DIN rail for easy installation in a NEMA enclosure. Connections to and from the module are made via removable screw-down wire terminals. Plug and play easy to use, this passive interface does not require any power to work. Inside is a Jensen high performance transformer that is able to withstand signal levels to +21 dBu at 20 Hz without discernible distortion. This provides galvanic isolation between the input and output to eliminate hum and buzz caused by ground loops, rejecting noise by as much as 120 dB.

Made for the most demanding professionals, the DIN-PC delivers a ruler flat response from 10 Hz to 140 kHz with less than 2° phase shift at all frequencies. This makes the DIN-PC ideal for converting balanced sources to unbalanced inputs for large scale installations in performance venues, broadcast houses and AV systems.

Applications

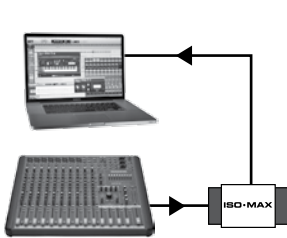

DIN-PC with a laptop

Use the DIN-PC to convert the balanced line level output from your mixing console to the unbalanced input on your laptop or sound card. The DIN-PC will manage the signal while eliminating hum and buzz caused by ground loops.

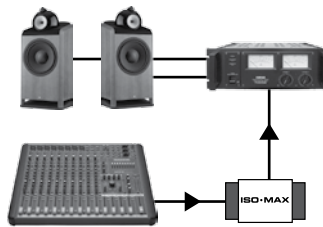

Pro-balanced signal to hi-fi

The Iso•Max DIN-PC is perfect for situations where you need to send a pro-balanced signal to a stereo hi-fi type input. Simply connect to the balanced inputs and output the -10 dB signal to feed the hi-fi system.

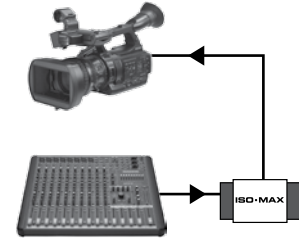

Audio interface for video camera

Capturing a live performance is easy using the DIN-PC as the audio interface between the mixing console and your video camera. Connect the console to the balanced inputs and send the unbalanced outputs to your camera.

Dimensions

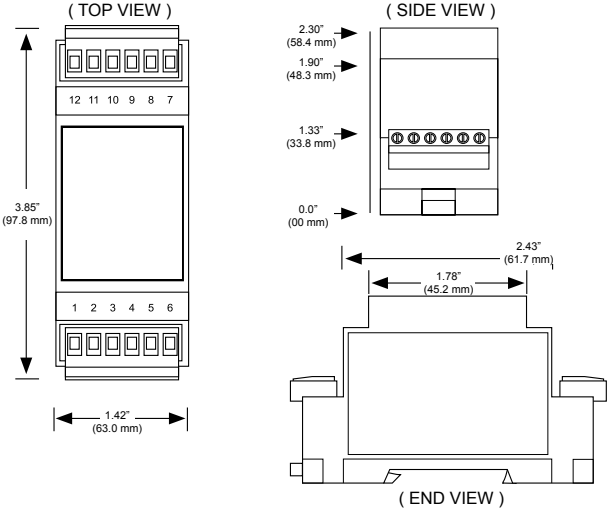

Module Schematic Diagram

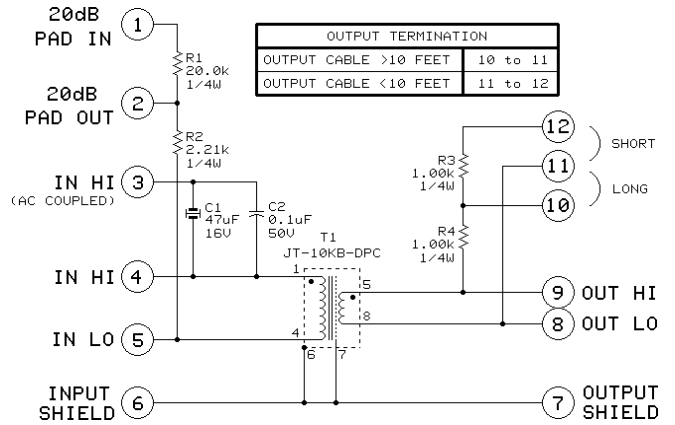

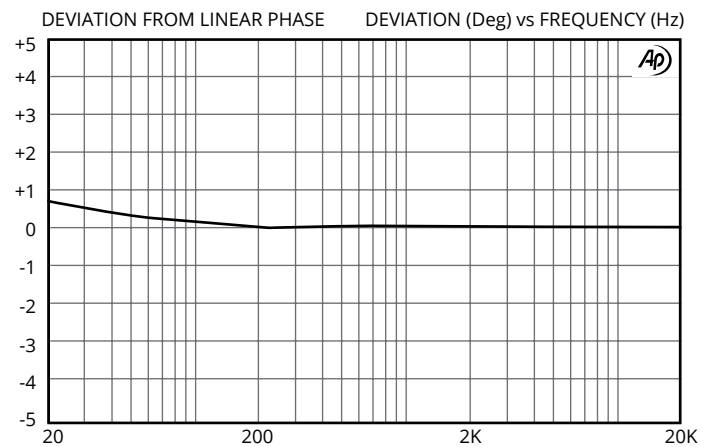
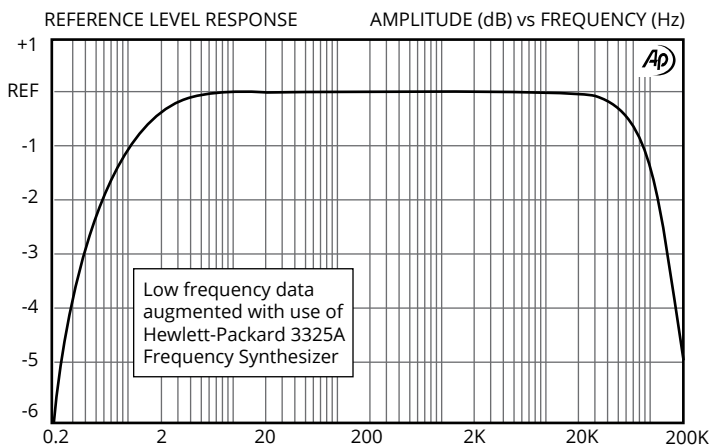
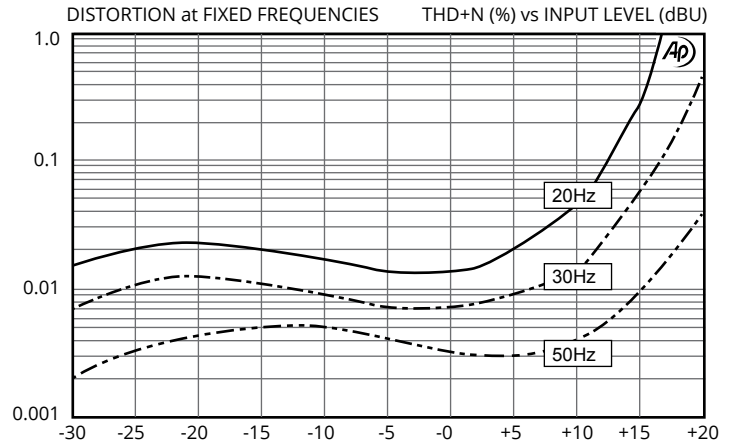
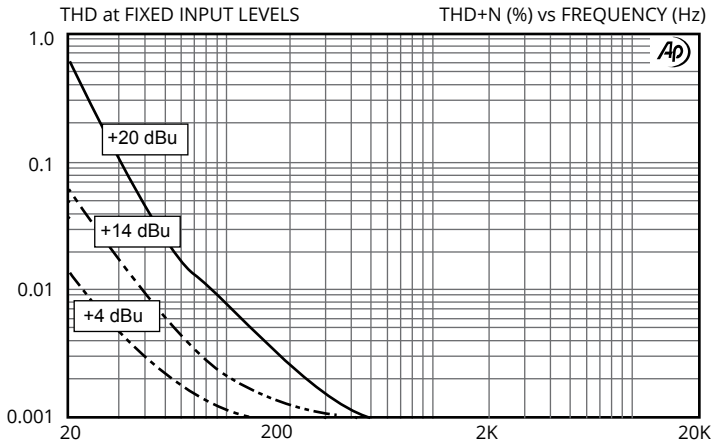

PARAMETER	CONDITIONS	MINIMUM	TYPICAL	MAXIMUM
Input impedance, Zi	1 kHz, +4 dBu, test circuit 1	39.4 kΩ	41.5 kΩ	43.6 kΩ
Voltage gain	1 kHz, +4 dBu, test circuit 1	-13.4 dB	-12.9 dB	-12.4 dB
Magnitude response, ref 1 kHz	20 Hz, +4 dBu, test circuit 1	-0.15 dB	-0.04 dB	±0.0 dB
	20 kHz, +4 dBu, test circuit 1	-0.15 dB	-0.03 dB	+0.1 dB
Deviation from linear phase (DLP)	20 Hz to 20 kHz, +4 dBu, test circuit 1		+0.6/-0.1°	±2.0°
Distortion (THD)	1 kHz, +4 dBu, test circuit 1		<0.001%	
	20 Hz, +4 dBu, test circuit 1		0.015%	0.05%
Maximum 20 Hz input level	1% THD, test circuit 1	+19 dBu	+21 dBu	
Common mode rejection ratio (CMRR) 50 Ω balanced source	60 Hz, test circuit 2		120 dB	
	3 kHz, test circuit 2	70 dB	85 dB	
Common mode rejection ratio (CMRR) 600 Ω unbalanced source	60 Hz, test circuit 3		90 dB	
	3 kHz, test circuit 3		55 dB	
Output impedance, Zo	1 kHz, test circuit 1		225 Ω	
Optimal cable length	output		1 m (3')	6 m (20')
Temperature range	operation or storage	0°C		70°C
Breakdown voltage*	primary to secondary to shield and case, 60 Hz, 1 minute test duration	250 V RMS		

All levels are input unless noted

Test Circuit 1:

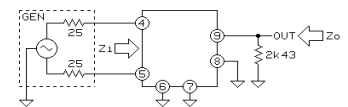

Test Circuit 2:

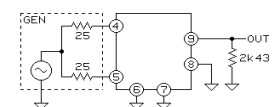

Test Circuit 3:

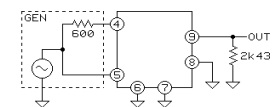

All minimum and maximum specifications are guaranteed. Unless noted otherwise, all specifications apply at 25°C. Specifications subject to change without notice. All information herein is believed to be accurate and reliable, however no responsibility is assumed for its use nor for any infringements of patents which may result from its use. No license is granted by implication or otherwise under any patent or patent rights of Jensen Transformers, Inc.

* IMPORTANT NOTE: THIS PRODUCT IS NOT INTENDED FOR USE IN CIRCUMSTANCES WHERE THE DC OR PEAK AC VOLTAGE BETWEEN INPUT AND OUTPUT CONNECTIONS EXCEEDS 34 VOLTS OR WHERE ITS FAILURE COULD CAUSE INJURY OR DEATH.