

DIN-DB Single channel direct box

- Convert unbalanced instrument signal to balanced
- Eliminates hum and buzz caused by ground loops
- Ruler flat frequency response from 10 Hz to 100 kHz
- Plug and play easy to use, no power required



The Iso•Max DIN-DB is a direct box designed to drive unbalanced instrument signals distances to 100 meters (300') or more without high frequency loss or introducing noise into the signal path.

The design begins with a gray molded assembly made from UL94-VO flame retardant Noryl that snaps into place onto a standard 35 mm DIN rail for easy installation in a NEMA enclosure. Connections to and from the module are made via removable screw-down wire terminals. Plug and play easy to use, this passive interface does not require any power to work. Inside is a Jensen high performance transformer providing galvanic isolation as it passively lowers the impedance and performs the balancing. A high 140 kΩ input impedance reduces loading, enabling low-output instruments such as a vintage Fender® bass to be connected without losing tone.

Made for the most demanding professionals, the DIN-DB delivers a ruler flat response from 10 Hz to 100 kHz with less than 2° phase shift. With over +21 dB of signal handling capacity, the DIN-DB gracefully handles extreme signals such as those produced by digital pianos while producing a warm Bessel response that is often referred to as 'vintage' sounding.

Applications

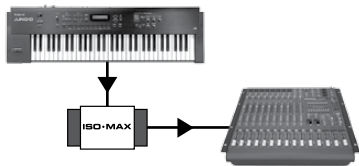

Passive Direct box with PA

Connect the hi-Z output from your keyboard to the DIN-DB and it will lower the impedance and balance the signal for long cable runs. It also eliminates hum and buzz caused by ground loops.

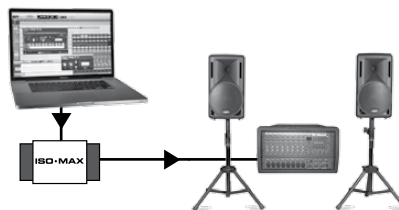

Laptop DI to PA system

Send the output from your laptop, CD player or DJ mixer to the DIN-DB and it will deliver a balanced mic level output to feed a mic splitter or the mic input of your mixing console without noise or distortion.

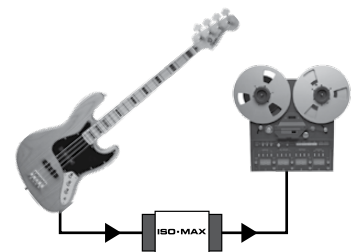

DIN-DB in the studio

The high input impedance, exceptional signal handling and broad frequency response make the DIN-DB a great choice for interfacing electric bass or acoustic guitar to the PA or recording system.

Dimensions

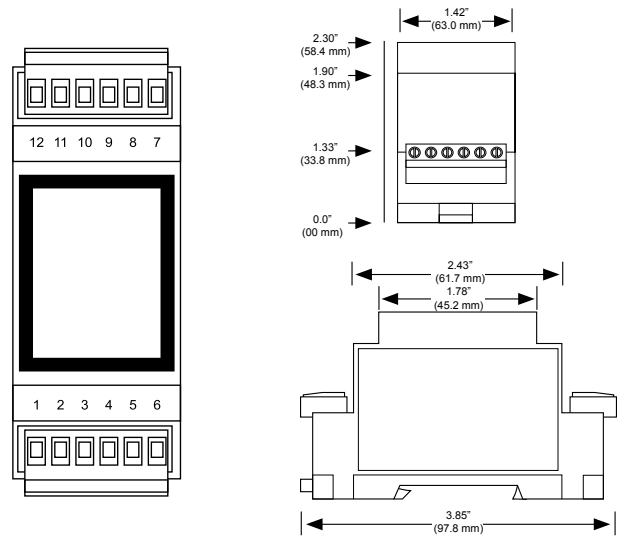

Module Schematic Diagram

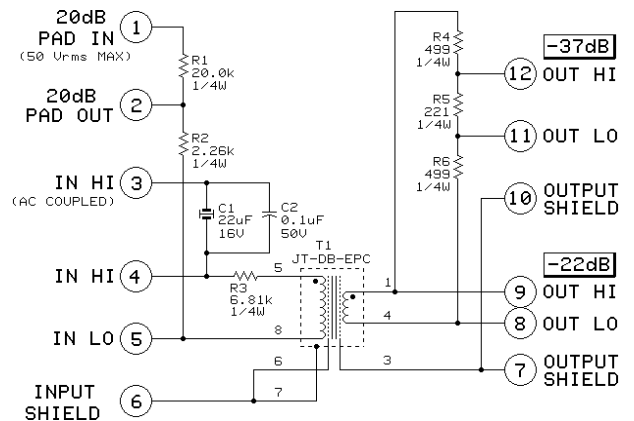

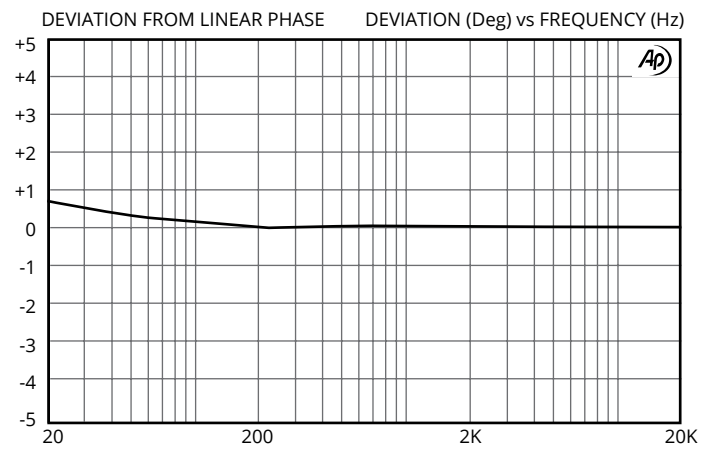
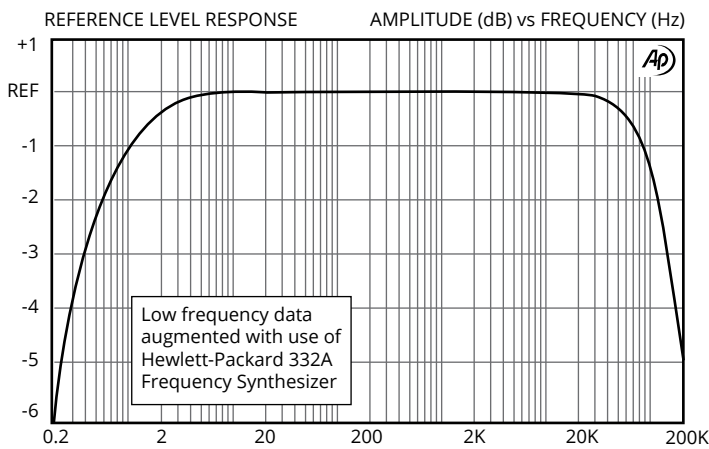
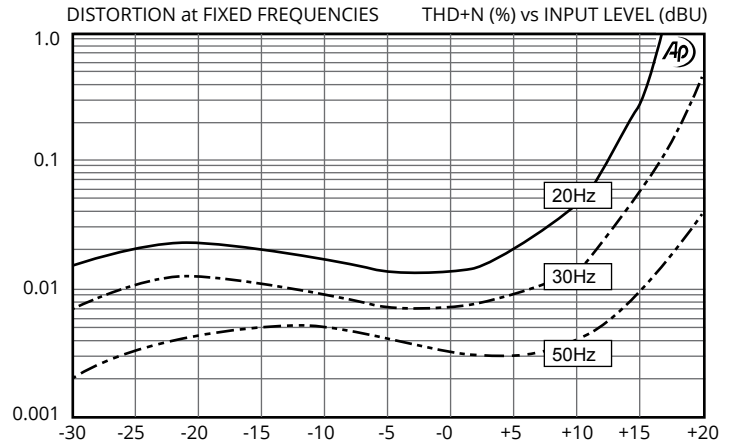
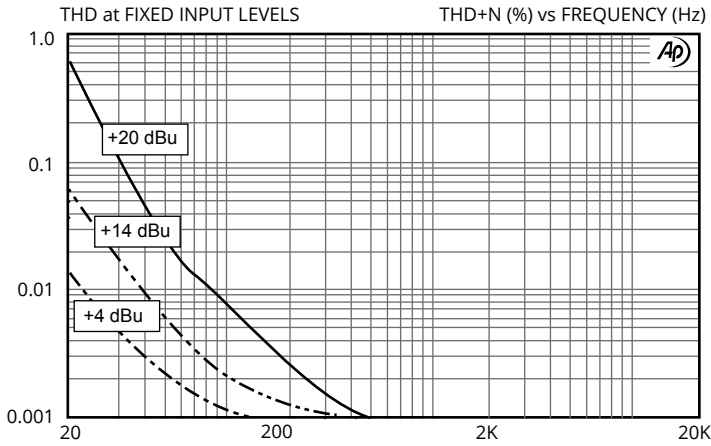

PARAMETER	CONDITIONS	MINIMUM	TYPICAL	MAXIMUM
Input impedance, Zi	1 kHz, +4 dBu, test circuit 1	39.4 kΩ	41.5 kΩ	43.6 kΩ
Voltage gain	1 kHz, +4 dBu, test circuit 1	-13.4 dB	-12.9 dB	-12.4 dB
Magnitude response, ref 1 kHz	20 Hz, +4 dBu, test circuit 1	-0.15 dB	-0.04 dB	±0.0 dB
	20 kHz, +4 dBu, test circuit 1	-0.15 dB	-0.03 dB	+0.1 dB
Deviation from linear phase (DLP)	20 Hz to 20 kHz, +4 dBu, test circuit 1		+0.6/-0.1°	±2.0°
Distortion (THD)	1 kHz, +4 dBu, test circuit 1		<0.001%	
	20 Hz, +4 dBu, test circuit 1		0.015%	0.05%
Maximum 20 Hz input level	1% THD, test circuit 1	+19 dBu	+21 dBu	
Common mode rejection ratio (CMRR) 50 Ω balanced source	60 Hz, test circuit 2		120 dB	
	3 kHz, test circuit 2	70 dB	85 dB	
Common mode rejection ratio (CMRR) 600 Ω unbalanced source	60 Hz, test circuit 3		90 dB	
	3 kHz, test circuit 3		55 dB	
Output impedance, Zo	1 kHz, test circuit 1		225 Ω	
Optimal cable length	input			
	output		1 m (3')	6 m (20')
Temperature range	operation or storage	0°C		70°C
Breakdown voltage*	primary to secondary to shield and case, 60 Hz, 1 minute test duration	250 V RMS		

All levels are input unless noted

* IMPORTANT NOTE: THIS PRODUCT IS NOT INTENDED FOR USE IN CIRCUMSTANCES WHERE THE DC OR PEAK AC VOLTAGE BETWEEN INPUT AND OUTPUT CONNECTIONS EXCEEDS 34 VOLTS OR WHERE ITS FAILURE COULD CAUSE INJURY OR DEATH.